**Industrial fans — Performance testing
*in situ***

Ventilateurs industriels — Essai de fonctionnement in situ

**iTeh STANDARD PREVIEW
(standards.iteh.ai)**

[ISO 5802:2001](https://standards.iteh.ai/catalog/standards/sist/e2956779-a61d-4545-ae5e-51cc6210cf94/iso-5802-2001)

<https://standards.iteh.ai/catalog/standards/sist/e2956779-a61d-4545-ae5e-51cc6210cf94/iso-5802-2001>



PDF disclaimer

This PDF file may contain embedded typefaces. In accordance with Adobe's licensing policy, this file may be printed or viewed but shall not be edited unless the typefaces which are embedded are licensed to and installed on the computer performing the editing. In downloading this file, parties accept therein the responsibility of not infringing Adobe's licensing policy. The ISO Central Secretariat accepts no liability in this area.

Adobe is a trademark of Adobe Systems Incorporated.

Details of the software products used to create this PDF file can be found in the General Info relative to the file; the PDF-creation parameters were optimized for printing. Every care has been taken to ensure that the file is suitable for use by ISO member bodies. In the unlikely event that a problem relating to it is found, please inform the Central Secretariat at the address given below.

iTeh STANDARD PREVIEW
(standards.iteh.ai)

[ISO 5802:2001](#)

<https://standards.iteh.ai/catalog/standards/sist/e2956779-a61d-4545-ae5e-51cc6210c94/iso-5802-2001>

© ISO 2001

All rights reserved. Unless otherwise specified, no part of this publication may be reproduced or utilized in any form or by any means, electronic or mechanical, including photocopying and microfilm, without permission in writing from either ISO at the address below or ISO's member body in the country of the requester.

ISO copyright office
Case postale 56 • CH-1211 Geneva 20
Tel. + 41 22 749 01 11
Fax + 41 22 749 09 47
E-mail copyright@iso.ch
Web www.iso.ch

Printed in Switzerland

Contents

Page

Foreword.....	v
Introduction.....	vi
1 Scope	1
2 Normative references	1
3 Terms, definitions and symbols	1
3.1 Terms and definitions	1
3.2 Symbols	14
4 Quantities to be measured	18
5 General conditions and procedures concerning <i>in situ</i> tests	18
5.1 General recommendations	18
5.2 Selection of test point when only the system resistance can be varied	18
5.3 Fans fitted with adjustment devices	19
5.4 System throttling devices allowing the system resistance to be altered	19
5.5 Selection of the test point when the system resistance cannot be varied	19
5.6 When correction of the coefficient deduced from the test is not necessary	20
6 Instrumentation	20
6.1 Instrumentation for measurement of pressure	20
6.2 Measurement of air velocity	21
6.3 Measurement of temperature	23
6.4 Determination of density	24
6.5 Measurement of rotational speed	25
7 Determination of fan pressure	25
7.1 Location of pressure measurement plane	25
7.2 Measurement of fan pressure	27
8 Determination of flow rate	36
8.1 Choice of measuring method	36
8.2 Choice of measuring section	36
8.3 Determination of flowrate using differential pressure devices	38
8.4 Determination of flowrate by velocity area methods	38
9 Determination of power	54
9.1 Definition of performance characteristics relating to the power of a fan	54
9.2 Losses during transmission of power from the motor to the impeller	56
9.3 Methods for determination of power	56
9.4 Measuring instruments	59
9.5 Precautions to be taken during <i>in situ</i> tests	59
10 Uncertainty associated with the determination of fan performance	59
10.1 General	59
10.2 Performance errors	60
10.3 Uncertainty of measurement	60
10.4 Specified uncertainties	60
10.5 Analysis of uncertainty	60
Annex A (normative) Position of exploration lines for a marginal wall profile compatible with a general power law	67
Annex B (normative) Determination of the position of the marginal exploration lines in cases not covered by annex A	71

Annex C (normative) Minimum straight lengths required upstream and downstream of the differential pressure devices (DP device) used for flow measurement.....	74
Annex D (normative) Loss allowance for straight, smooth ducts and standardized airways	82
Annex E (normative) Rotating vane anemometer calibration.....	84
Bibliography	86

iTeh STANDARD PREVIEW
(standards.iteh.ai)

[ISO 5802:2001](https://standards.iteh.ai/catalog/standards/sist/e2956779-a61d-4545-ae5e-51cc6210cf94/iso-5802-2001)

<https://standards.iteh.ai/catalog/standards/sist/e2956779-a61d-4545-ae5e-51cc6210cf94/iso-5802-2001>

Foreword

ISO (the International Organization for Standardization) is a worldwide federation of national standards bodies (ISO member bodies). The work of preparing International Standards is normally carried out through ISO technical committees. Each member body interested in a subject for which a technical committee has been established has the right to be represented on that committee. International organizations, governmental and non-governmental, in liaison with ISO, also take part in the work. ISO collaborates closely with the International Electrotechnical Commission (IEC) on all matters of electrotechnical standardization.

International Standards are drafted in accordance with the rules given in the ISO/IEC Directives, Part 3.

Draft International Standards adopted by the technical committees are circulated to the member bodies for voting. Publication as an International Standard requires approval by at least 75 % of the member bodies casting a vote.

Attention is drawn to the possibility that some of the elements of this International Standard may be the subject of patent rights. ISO shall not be held responsible for identifying any or all such patent rights.

International Standard ISO 5802 was prepared by Technical Committee ISO/TC 117, *Industrial fans*.

Annexes A to E form a normative part of this International Standard.

iTeh STANDARD PREVIEW
(standards.iteh.ai)

[ISO 5802:2001](https://standards.iteh.ai/catalog/standards/sist/e2956779-a61d-4545-ae5e-51cc6210c94/iso-5802-2001)

<https://standards.iteh.ai/catalog/standards/sist/e2956779-a61d-4545-ae5e-51cc6210c94/iso-5802-2001>

Introduction

The need to revise existing methods of site testing has been apparent for some time. Bearing in mind the extent of these revisions, it was felt appropriate to expand the method of site testing into a "stand-alone" document. This would enable the velocity area methods to be fully detailed for all commonly encountered airway cross-sections. It would also allow the addition of descriptive annexes covering the selection of suitable measuring stations and instrument calibration.

In accordance with recent International agreements, it will be noted that fan pressure is now defined as the difference between stagnation pressure at the fan inlet and outlet. Stagnation pressure is the absolute pressure which would be measured at a point in a flowing gas if it were brought to rest isentropically. For Mach numbers less than 0,2 the gauge stagnation pressure is within 0,6 % of the total pressure.

Less emphasis is placed on the use of "fan static pressure" as this is a conventional quantity only. It is to be anticipated that its use will cease with time. All fluid losses are essentially losses in stagnation pressure and this has been reflected in the definitions now specified.

It should be recognized that the performance of a fan measured under site conditions will not necessarily be the same as that determined from tests using standardized airways. The reasons for such differences are not only due to the inherently lower accuracy of a site test, but also due to the so-called "system effect factor" or "installation effect", where the ducting connections at fan inlet and/or outlet modify its performance. The need for good connections cannot be understated. This International Standard specifies the use of "common parts" immediately adjoining the fans for the consistent determination of pressure and also to ensure that air/gas is presented to the fan as a symmetrical velocity profile free from swirl and undue distortion. Only if these conditions are met, will the performance under site conditions equate with those measured in standardized airways.

[ISO 5802:2001](#)

It should also be noted that this International Standard specifies the positioning of velocity-area measuring points according to log-Tchebycheff or log-linear rules. Arithmetic spacing can lead to considerable error unless a very high number of point readings are taken. (These would then have to be plotted graphically and the area under the curve obtained using planimetry. The true average velocity would be this area divided by the dimensional ordinates).

It is outside the scope of this International Standard to assess the additional uncertainty where the lengths of straight duct either side of the measuring station are less than those specified in annex C. Guidance is, however, given in ISO/TR 5168 and ISO 7194, from which it will be seen that where a significant radial component exists, uncertainties can considerably exceed the normally anticipated 4 % at 95 % confidence levels.

Industrial fans — Performance testing *in situ*

1 Scope

This International Standard specifies tests for determining one or more performance characteristics of fans installed in an operational circuit when handling a monophase fluid.

2 Normative references

The following normative documents contain provisions which, through reference in this text, constitute provisions of this International Standard. For dated references, subsequent amendments to, or revisions of, any of these publications do not apply. However, parties to agreements based on this International Standard are encouraged to investigate the possibility of applying the most recent editions of the normative documents indicated below. For undated references, the latest edition of the normative document referred to applies. Members of ISO and IEC maintain registers of currently valid International Standards.

ISO 5167-1:1991, *Measurement of fluid flow by means of pressure differential devices — Part 1: Orifice plates, nozzles and Venturi tubes inserted in circular cross-section conduits running full.*

ISO 5801:1997, *Industrial fans — Performance testing using standardized airways.*

IEC 60034-1, *Rotating electrical machine — Part 1: Rating and performance.*

IEC 60051-8, *Direct acting indicating analogue electrical measuring instruments and their accessories — Part 8: Special requirements for accessories.*

3 Terms, definitions and symbols

3.1 Terms and definitions

For the purposes of this International Standard, the following terms and definitions apply.

The quantities referred to are time-averaged mean values. Fluctuations which affect the quantities being measured may be accounted for by repeating measurements at appropriate time intervals. Mean values may then be calculated which are taken as the steady-state value.

3.1.1

air

air or other gas, except when specifically referred to as atmospheric air

3.1.2

standard air

atmospheric air having a density of exactly $1,2 \text{ kg}\cdot\text{m}^{-3}$

NOTE Atmospheric air at a temperature of $16 \text{ }^\circ\text{C}$, a pressure of $100\,000 \text{ Pa}$ and a relative humidity of 65% , has a density of $1,2 \text{ kg}\cdot\text{m}^{-3}$, but these conditions are not part of the definition.

3.1.3

fan

rotary machine which maintains a continuous flow of air at a pressure ratio not normally exceeding 1,3

3.1.4

impeller

rotating part of a fan which, by means of its blades, transfers energy to the air

3.1.5

casing

those stationary parts of a fan which direct the flow of air from the fan inlet opening(s) to the fan outlet opening(s)

3.1.6

duct

airway in which the air velocity is comparable with that at the fan inlet or outlet

3.1.7

chamber

airway in which the air velocity is small compared with that at the fan inlet or outlet

3.1.8

**transition piece
section**

airway along which there is a gradual change of cross-sectional area and/or shape

3.1.9

test enclosure

room, or other space protected from draught, in which the fan and test airways are situated

3.1.10

area of the conduit section

A_x

area of the conduit at section x

iTeh STANDARD PREVIEW
(standards.iteh.ai)

[ISO 5802:2001](https://standards.iteh.ai/catalog/standards/sist/e2956779-a61d-4545-ae5e-51cc6210c94/iso-5802-2001)

<https://standards.iteh.ai/catalog/standards/sist/e2956779-a61d-4545-ae5e-51cc6210c94/iso-5802-2001>

3.1.11

fan inlet area

A_1

by convention, the gross area in the inlet plane inside the casing

NOTE The fan inlet plane should be taken as that surface bounded by the upstream extremity of the air moving device. In this International Standard the fan inlet plane is indicated by plane 1 (see Figure 1).

3.1.12

fan outlet area

A_2

by convention, the gross area in the outlet plane inside the casing without deduction for motors, fairings or other obstructions

NOTE The fan outlet plane should be taken as that surface bounded by the downstream extremity of the air moving device. In this International Standard the outlet is indicated by plane 2 (see Figure 1).

3.1.13

temperature

t

air or fluid temperature measured by a temperature sensor

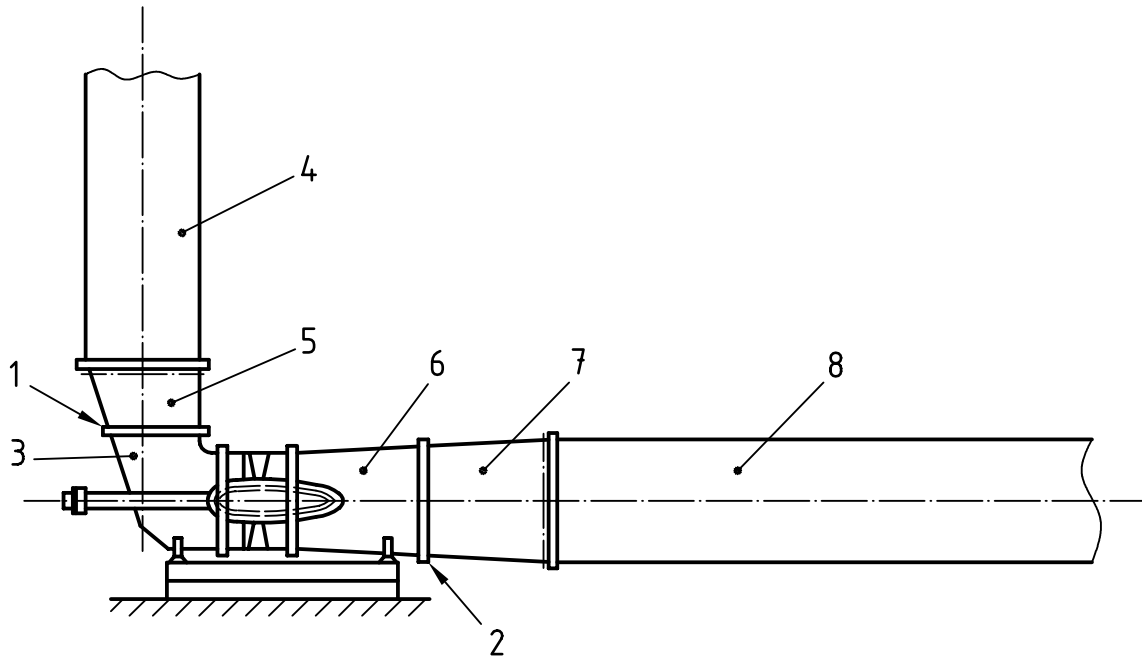

a) Axial fan

iTeh STANDARD PREVIEW
(standards.iteh.ai)

ISO 5802:2001

<https://standards.iteh.ai/catalog/standards/sist/e2956779-a61d-4545-ae5e-51cc6210cf94/iso-5802-2001>

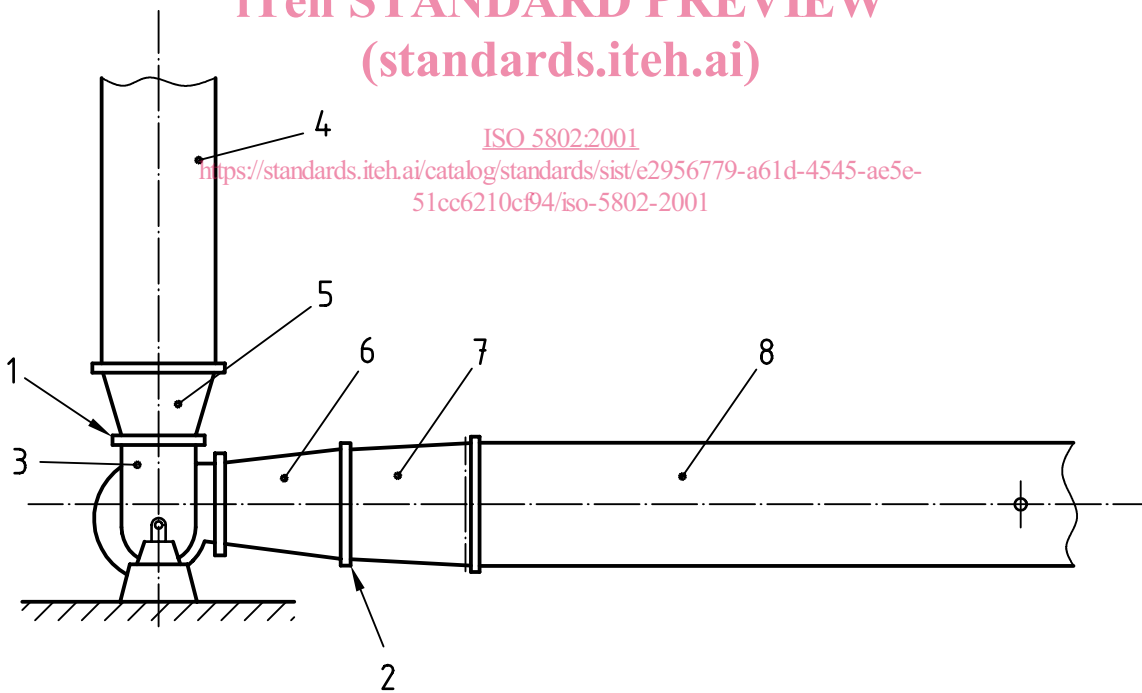

b) Centrifugal fan

Key

- | | | | |
|---|------------|---|-------------|
| 1 | Plane 1 | 5 | Transition |
| 2 | Plane 2 | 6 | Diffuser |
| 3 | Inlet box | 7 | Transition |
| 4 | Inlet duct | 8 | Outlet duct |

Figure 1 — Location of pressure measurement planes for site testing

**3.1.14
absolute temperature**

θ
thermodynamic temperature measured above absolute zero

$$\theta = t + 273,15$$

**3.1.15
stagnation temperature at a point**

θ_{sg}
absolute temperature which results if an ideal gas flow is brought to rest isentropically without addition of energy or heat

NOTE The stagnation temperature is constant along an airway, and for an inlet duct is equal to the absolute ambient temperature in the test enclosure.

**3.1.16
static or fluid temperature**

θ
absolute temperature of a thermal sensor moving at the fluid velocity

$$\theta = \theta_{sg} - \frac{v^2}{2c_p}$$

where v is the fluid velocity (m/s)

STANDARD PREVIEW
(standards.iteh.ai)

**3.1.17
dry bulb temperature**

t_d
air temperature measured by a dry temperature sensor in the test enclosure, near the fan inlet or airway inlet

ISO 5802:2001

51cc6210c94/iso-5802-2001

**3.1.18
wet bulb temperature**

t_w
air temperature measured by a temperature sensor covered by a water-moistened wick and exposed to air in motion

NOTE When properly measured, it is a close approximation of the temperature of adiabatic saturation.

**3.1.19
stagnation temperature at a section**

θ_{sgx}
mean value in time of the stagnation temperature averaged over the area of the specified airway cross section

**3.1.20
static or fluid temperature at a section**

θ_x
mean value in time of the static or fluid temperature averaged over the area of the specified airway cross section

**3.1.21
specific gas constant**

R
for an ideal gas, the equation of state is written

$$\frac{p}{\rho} = R\theta$$

3.1.22 inlet stagnation temperature

θ_{sg1}

temperature in the test enclosure near the fan inlet or the inlet duct at a section where the fluid velocity is less than 25 m/s

NOTE In this case the stagnation temperature may be considered equal to the ambient temperature

$$\theta_{sg1} = \theta_a = t_a + 273,15$$

3.1.23 isentropic exponent

κ

for an ideal gas and an isentropic process

$$\frac{p}{\rho^\kappa} = \text{constant}$$

3.1.24 specific heat at constant pressure

c_p

for an ideal gas:

$$c_p = \frac{\kappa}{\kappa - 1} R$$

iTeh STANDARD PREVIEW
(standards.iteh.ai)

3.1.25 specific heat at constant volume

c_v

for an ideal gas

[ISO 5802:2001](https://standards.iteh.ai/catalog/standards/sist/e2956779-a61d-4545-ae5e-51cc6210cf94/iso-5802-2001)

<https://standards.iteh.ai/catalog/standards/sist/e2956779-a61d-4545-ae5e-51cc6210cf94/iso-5802-2001>

$$c_v = \frac{R}{\kappa - 1}$$

3.1.26 compressibility factor

Z

$$Z = \frac{p}{\rho R \theta}$$

and Z is a function of the ratios $\frac{p}{p_c}$ and $\frac{\theta}{\theta_c}$

where

p_c is the critical pressure of the gas

θ_c is the critical temperature of the gas

NOTE For an ideal gas $Z = 1$.

3.1.27 absolute pressure at a point

p

pressure measured from absolute zero, which is exerted at a point at rest relative to the air around it

**3.1.28
atmospheric pressure**

p_a
absolute pressure of the free atmosphere at the mean altitude of the fan

**3.1.29
gauge pressure**

p_e
value of a pressure when the datum pressure is the atmospheric pressure at the point of measurement

NOTE It may be negative or positive:

$$p_e = p - p_a$$

**3.1.30
absolute stagnation pressure at a point**

p_{sg}
absolute pressure which would be measured at a point in a flowing gas if it were brought to rest via an isentropic process

$$p_{sg} = p \left(1 + \frac{\kappa - 1}{2} Ma^2 \right)^{\frac{\kappa}{\kappa - 1}}$$

where Ma is the Mach number at this point

**3.1.31
dynamic pressure at a point**

p_d
pressure calculated from the velocity v and the density ρ of the air at the point

$$p_d = \frac{\rho v^2}{2}$$

**3.1.32
total pressure at a point**

p_t
absolute stagnation pressure minus the atmospheric pressure

$$p_t = p_{sg} - p_a = p_e + p_d$$

NOTE When the Mach number is less than 0,2, the Mach factor is less than 1,01 and the absolute stagnation pressure p_{sg} is very close to the sum of the gauge pressure, the atmospheric pressure and the dynamic pressure:

$$p_{sg} \cong p_e + p_a + p_d$$

**3.1.33
average gauge pressure at a section x**

p_{ex}
mean value in time of the gauge pressure averaged over the area of the specified airway cross section

**3.1.34
average absolute pressure at a section x**

p_x
mean value in time of the absolute pressure averaged over the area of the specified airway cross section

$$p_x = p_{ex} + p_a$$

3.1.35 conventional dynamic pressure at a section x

p_{dx}

dynamic pressure calculated from the average velocity and the average density at the specified airway cross section

$$p_{dx} = \rho_x \frac{v_{mx}^2}{2} = \frac{1}{2\rho_x} \left(\frac{q_m}{A_x} \right)^2$$

3.1.36 fan dynamic pressure

p_{dF}

conventional dynamic pressure at the fan outlet calculated from the mass flow, the average air density at the outlet and the fan outlet area

$$p_{dF} = \rho_2 \frac{v_{m2}^2}{2} = \frac{1}{2\rho_2} \left(\frac{q_m}{A_2} \right)^2$$

3.1.37 absolute stagnation pressure at a section x

p_{sgx}

sum of the conventional dynamic pressure p_{dx} corrected by the Mach factor coefficient F_{Mx} at the section and the average absolute pressure p_x

$$p_{sgx} = p_x + p_{dx} F_{Mx}$$

ITeh STANDARD PREVIEW
(standards.iteh.ai)

NOTE The absolute stagnation pressure may be calculated by the expression:

[ISO 5802:2001](https://standards.iteh.ai/catalog/standards/sist/e2956779-a61d-4545-ae5e-51cc6210c94/iso-5802-2001)

$$p_{sgx} = p_x \left(1 + \frac{\kappa - 1}{2} Ma_x^2 \right)^{\frac{\kappa}{\kappa - 1}}$$

3.1.38 average total pressure at a section x

p_{tx}

when the Mach number is less than 0,122, the Mach factor F_M may be neglected so

$$p_{tx} = p_{ex} + p_{dx} = p_{sgx} - p_a$$

3.1.39 fan pressure

p_F

difference between the stagnation pressure at the fan outlet and the stagnation pressure at the fan inlet

$$p_F = p_{sg2} - p_{sg1}$$

3.1.40 fan static pressure

p_{sF}

conventional quantity defined as the fan pressure minus the fan dynamic pressure corrected by the Mach factor at the fan outlet area

$$p_{sF} = p_{sg2} - p_{dF} F_{M2} - p_{sg1} = p_2 - p_{sg1}$$

3.1.41

Mach number at a point

Ma

ratio of the fluid velocity at a point and the velocity of sound in the fluid

NOTE For an ideal gas:

$$Ma = \frac{v}{\sqrt{\kappa R_w \theta}}$$

3.1.42

Mach number at a section x

Ma_x

ratio of the fluid average velocity by the velocity of sound at the specified airway cross section

$$Ma_x = \frac{v_{mx}}{\sqrt{\kappa R_w \theta_x}}$$

3.1.43

Mach factor

F_M

correction factor which is applied to the dynamic pressure at a point given by the expression

$$F_M = \frac{p_{sg} - p}{p_d}$$

iTeh STANDARD PREVIEW
(standards.iteh.ai)

NOTE The Mach factor may be calculated by:

$$F_M = 1 + \frac{Ma^2}{4} + \frac{Ma^4}{40} + \frac{Ma^6}{1600} + \dots$$

ISO 5802:2001
for $\kappa = 1.4$
<http://standards.iteh.ai/catalog/standards/sist/e2956779-a61d-4545-ae5e-51cc6210c94/iso-5802-2001>

3.1.44

stagnation inlet density

ρ_{sg1}

density calculated from the stagnation inlet pressure p_{sg1} and the stagnation inlet temperature θ_{sg1}

$$\rho_{sg1} = \frac{p_{sg1}}{R_w \theta_{sg1}}$$

3.1.45

average density at a section x

ρ_x

fluid density calculated from the absolute pressure p_x and the static temperature θ_x

$$\rho_x = \frac{p_x}{R_w \theta_x}$$

3.1.46

mean density

ρ_m

arithmetic mean value of inlet and outlet densities

$$\rho_m = \frac{\rho_1 + \rho_2}{2}$$

3.1.47 mean mass flowrate at a section

q_m

mean value over time of the mass of fluid which passes through the specified airway cross section per unit of time

NOTE The mass flow will be the same at all cross sections within the fan airway system, apart from leakage. When the fan is not gastight, the mass flow is taken as either that at the fan inlet or outlet, as appropriate.

3.1.48 inlet stagnation volume flow

q_{Vsg1}

mass flowrate divided by the stagnation inlet density

$$q_{Vsg1} = \frac{q_m}{\rho_{sg1}}$$

3.1.49 outlet stagnation volume flow

q_{Vsg2}

mass flowrate divided by the stagnation outlet density

$$q_{Vsg2} = \frac{q_m}{\rho_{sg2}}$$

3.1.50 volume flow at a section x

q_{Vx}

mass flow at the specified airway cross section divided by the corresponding mean value in time of the average density at that section

[ISO 5802:2001](https://standards.iteh.ai/catalog/standards/sist/e2956779-a61d-4545-ae5e-51cc6210c94/iso-5802-2001)

<https://standards.iteh.ai/catalog/standards/sist/e2956779-a61d-4545-ae5e-51cc6210c94/iso-5802-2001>

$$q_{Vx} = \frac{q_m}{\rho_x}$$

iTeh STANDARD PREVIEW
(standards.iteh.ai)

3.1.51 average velocity at a section x

v_{mx}

volume flow at the specified airway cross section divided by the cross-sectional area A

$$v_{mx} = \frac{q_{Vx}}{A_x}$$

NOTE This is the mean value over time of the average component of the fluid velocity normal to that section.

3.1.52 fan work per unit mass

y

mechanical energy increment per unit mass of the fluid passing through the fan

$$y = \frac{p_2 - p_1}{\rho_m} + \frac{v_{m2}^2}{2} - \frac{v_{m1}^2}{2}$$

NOTE y may be calculated as in 3.1.57.